

Chapter 1

A BASIC USER'S GUIDE TO THE SERGE TCHEREPNIN SYNTHESIZER

- I. A. General - There are 16 separate modules
- B. Jacks - Blue - either In or Out - are 0 to +5v. control Signals - All blue plugs are direct coupled and input or output voltages from DC to over 20 Kc.
- Silver - Either In or Out - are audio voltages - bipolar referenced to ground (3½ v. p:-p. max.) Silver jacks as inputs block DC and attenuate AC frequencies below 30 cps.
- Red - Either In or Out - are pulses (0 to 5v. nominal)

D. Face Plates -

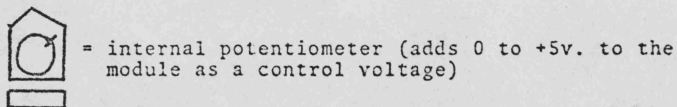
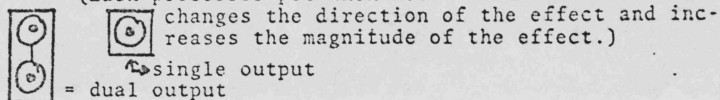
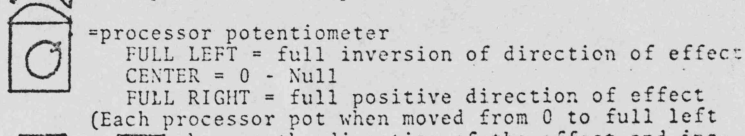
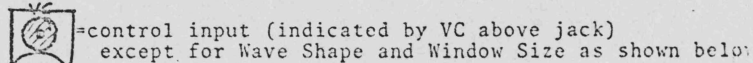
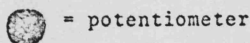
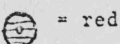
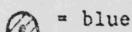
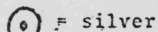
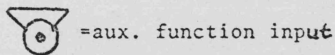
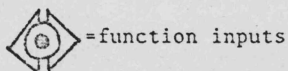

and



Auxiliary Control Voltage Inputs

MOST IMPORTANT RULE - NEVER, NEVER

1. NEVER CONNECT AN OUTPUT TO AN OUTPUT
2. NEVER CONNECT AN INPUT TO AN INPUT

In proper patching sequence however all voltage levels may be freely mixed. Equipment is equipped to handle that.

II. The Modules:

1. The Oscillator

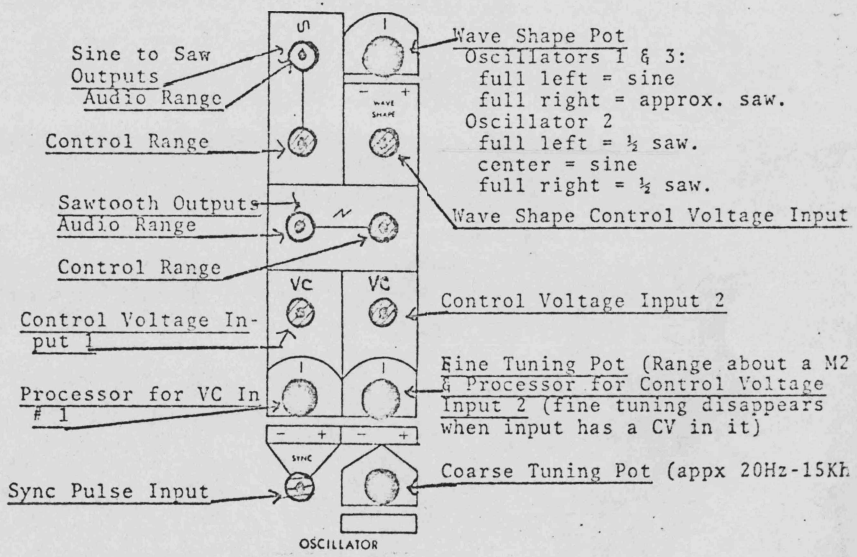

Oscillator

Puts out simultaneously two wave forms - one a sawtooth wave, and the other a sine to approximate saw wave, both at the same frequency. These are controlled by the frequency pot, (an internal pot) and 0, 1 or 2 control voltages. The control range of the oscillator is 1/2 volt/octave. The rightmost processor pot for the control voltages, when not accepting a control voltage, is a fine tuning pot with a range of a major second. The variable wave form's shape is controlled by an internal pot and a control voltage.

Sync inputs permit the synchronizing of any two oscillators, or of an oscillator with any other pulse source - (i.e., voice or video thru comparator or slew limiters or whatever). By applying a voltage to the control input of the oscillator which is being synchronized, that oscillator will only be able to produce frequencies which are along the harmonic series of the synchronizing oscillator. Generation of sub-harmonics is equally possible.

2. COMPARATOR

(a triple unit)

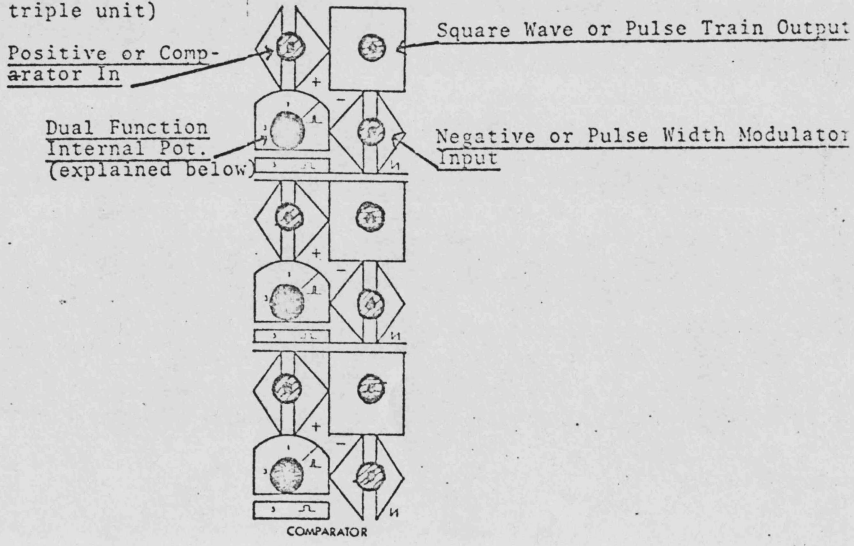

A comparator is any circuit which compares two inputs. If A (+input) > B (-in) a logic 1 (or in this case 5 volts) results. If B (-in) > A (+ in) - a logic 0 results. (0 volts). The internal pot on the comparator adds between 0 and 5 volts to the positive or comparator input. The numbers 1, 3, 5 on the potentiometer label indicate this. At the diagonal line dividing the 1, 3, 5 from the square waves, 0 volts are added to the positive input.

The comparator has basically 3 functions, as a pulse width modulator, a squarer and a logic comparator.

1. Pulse Width Modulator: Put a sawtooth wave into the negative or pulse width modulator in. The 2 square wave drawings next to the internal pot show the pulse widths obtainable. Full right is a square wave. The 2 o'clock diagonal line is a very narrow pulse wave. The knob moved left beyond this line will have no effect. The narrow pulse will continue. In this mode the positive input can be used as a control voltage input into the pulse width modulator. When this is done the pot will act as a processor, of sorts. Experimentation will reveal the full extent of this.
2. Squarer: Put a constant /^{freq} pulse or sawtooth wave into the negative or pulse width modulator in. Turn the knob full right. The output will be a square wave.
3. Comparator: Plug a signal (sawtooth wave) into the positive input with the knob full left. The result will be a square wave. When the knob is turned to 1, a very narrow pulse results. When the knob is turned to zero - silence. - 0 volts are added to the positive input - the positive will always be higher than the negative, so the output will always be +5 volts. Again experimentation will reveal the full effect of this knob. Note: The narrowest pulse on this module is given out by the middle comparator. Other uses of the comparator include logic switching in a large patch (i.e., when A reaches level X, control voltage B is turned on), voice encoding (or any kind of mike input); outside world interfacing (i.e., video, computer). Serge suggests: A-VIDEO-NOTE: Always use comparator for interfacing video with the synthesizer and NEVER use video pulses to drive the ENVELOPE Generators.

SCHMITT TRIGGER

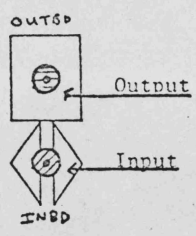

This is a non-integrating Schmitt Trigger which is an adjunct to the comparators.

.5 volts is the minimum triggering threshold.

4.5 volt is the maximum triggering threshold.

WAVESHAPER (a triple module)

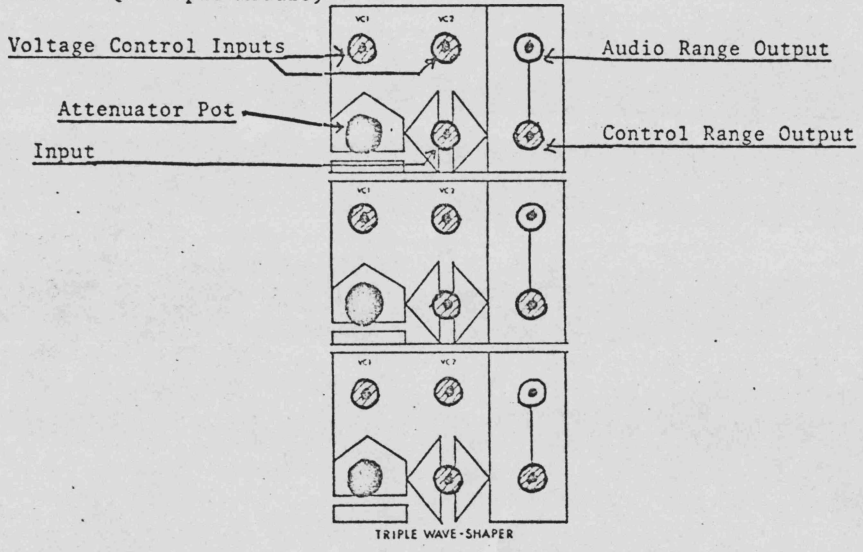

WAVESHAPER - A triple module.

The input can be any audible waveform. The output is a distorted form of that wave, basically, a full wave rectification with a lot of non-linearities. A triangle can be converted to a sine wave at 2F. A saw can result in an approximate sine at 1F. The pot is an input attenuator. The two control voltage inputs affect two different aspects of the wave distortion and are equally affected by the attenuator pot. Each input affects differently the specific non-linearities involved. It may increase a certain kind of non-linearity and decrease another. The wave shaper is basically a distortion module with various areas of distortion voltage controllable. When using the control voltage inputs, at times the sound output may disappear. This is because certain non-linearities may have been driven to the saturation point. This will be different with each sound, so experimentation is the best way to deal with this. The solution is usually attenuation of the incoming control voltage.

4. MIXER (Dual Module)

3 inputs with pots which attenuate to 0 full left. Below dual Outs is a unity gain that adds, at unity gain the input to the audio inputs. This may be used for cascading mixers, etc.

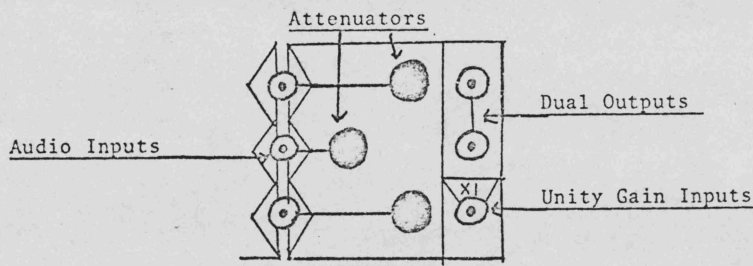

5. FILTER

The filter accepts an AC signal and simultaneously outputs 3 signals: A low-pass (12 db/oct); a high pass (12 db/oct) and a band pass with fixed band width. These 3 outputs are all centered around a common frequency which is controlled by an internal pot and a control voltage. A Gain Pot is placed below the input. A Processor Pot is placed below the control voltage input. The Q is varied by an internal pot placed next to the input and is not voltage controlled. The Q is Lowest at full right.

The filter can also be used as a very pure sine wave oscillator with the Q up and one of the band pass outputs fed back into the audio input.

Another interesting effect is with the input signal fully attenuated and the Q upfull-a rapidly changing control voltage input will produce a series of water drop type sounds from the low-pass output.

FILTER

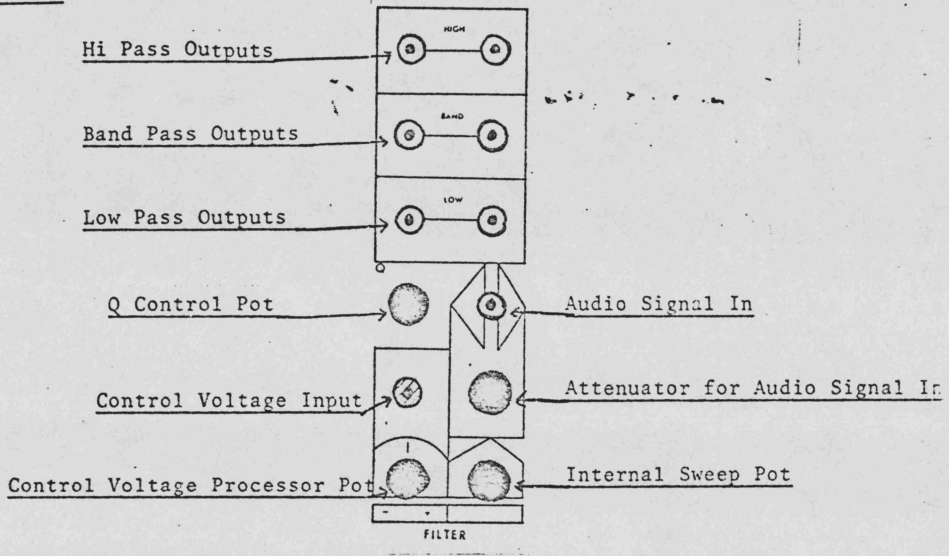

RING MODULATOR

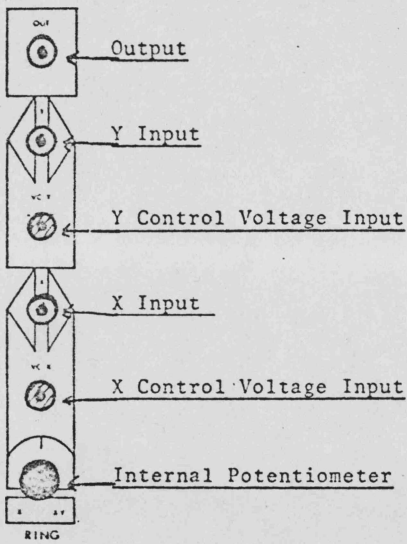

2 inputs are accepted (X & Y).
 Output moves from X only to
 X amplitude modulating Y; to
 Ring Modulating Y depending on
 the position of the pot. The
 control voltage under X, when
 high, lets X pass thru unsuppress.
 The same is true for Y.

THE GATES

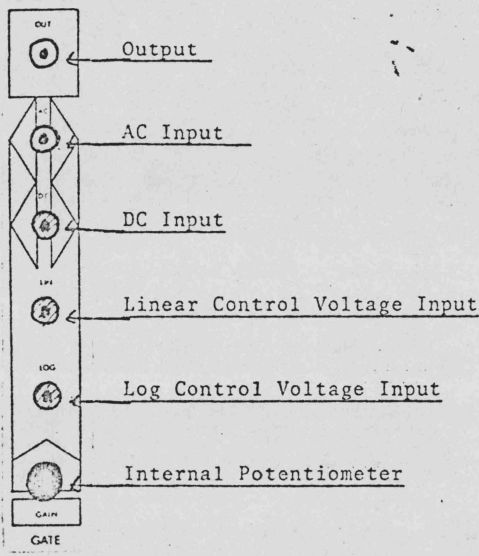

The gates have many modes of operation. As a standard AC gate, signal enters AC input and exits from the output. The pot controls gain and is an offset to the control inputs. The log control opens the gates in a logarithmic way (as in traditional gates), the LIN in, in a Linear Way.

When both are used, the Lin acts as a scaler for the Log. (The greater the Lin in the less the Log in)

This module can also control DC by inputting the voltage into the DC input. the control works as in the AC mode, and acts as a control voltage multiplier (linear V.C.X.V.C. = VC/5).

BI-DIRECTIONAL ROUTER(triple module)

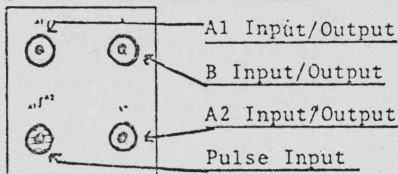

This module has 2 modes:

1. An input into A1 and an input into A2. Output is taken at B. When pulse input goes high, output at B is A2 input. When low, output at B is A1 input.
2. Input into B. Outputs taken at A1 and A2. When pulse input is high, output B passes out A2, when low, output B passes out A1.

This module can be used at practically any speed.

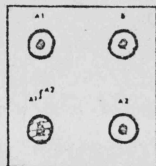

BI-DIRECTIONAL ROUTER

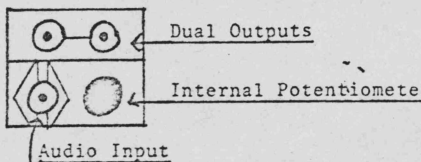
HI GAIN AMPS (Dual Module)

This is a simple amplifier which, when the internal potentiometer is in full right position boosts almost any system AC signal to approx. 28V. p-p.

For this reason EXTREME CARE should be used when USING THIS MODULE. A typical use of this module is the obtaining of distortions and color saturations in video, or boosting 10 control voltages to higher levels for interface purposes.

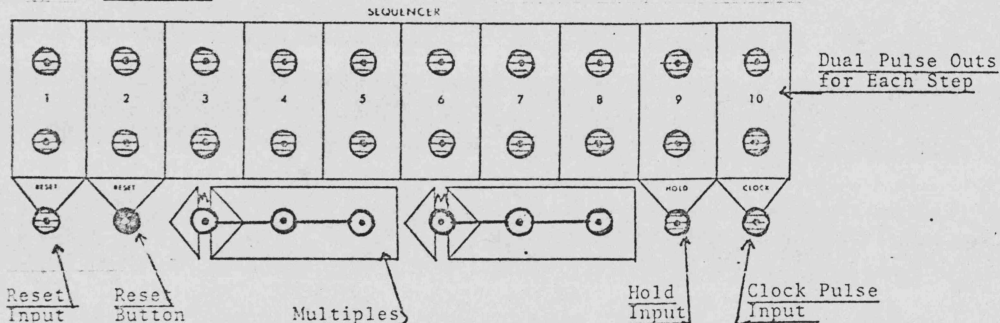
SEQUENCER (Dual Module)

This is a pulse out sequencer. That is, of the 10 stages only one stage is high (+5v.) at any instant. Every time a pulse enters CLOCK, the next stage goes on, and the previous stage goes off, until stage 10 is reached. Then the next pulse into CLOCK sends the sequencer back to stage 1. The RESET in (accepts 5v. pulse) and the push button both bring the pulse back to stage 1. The HOLD overrides the CLOCK and keeps the sequencer from moving.

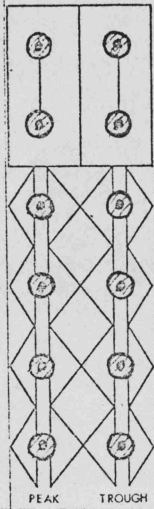

PEAK & TROUGH TRACER (2 Distinct modules)

Dual Peak Outs

Dual Trough Outs

Peak Ins

Trough Ins

PEAK Accepts 4 Inputs AC or DC. It passes as output whichever signal is highest at any given instant. Can be used as a non-linear mixer, or an interesting control voltage adder.

TROUGH: Same as peak, except it passes the lowest positive input voltage.

ENVELOPE GENERATOR

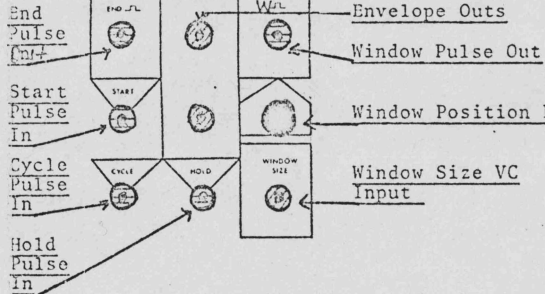

The rise time of the generator is controlled by the rise pot, the fall times by the fall pot. In both cases full right = minimum time, approx. 1/1000 sec. Full left = maximum time: approx. 6 mins.

Total duration (rise and fall together) can be controlled by the control voltage in DURATION VC IN and its associated VC Processor Pot.

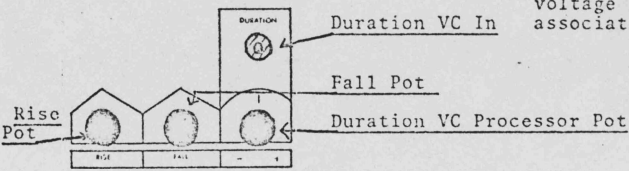

ENVELOPE GENERATOR

Start pulse in re-starts the envelope generator every time a pulse is applied to it, unless the envelope is not finished.

Cycle pulse in - if the cycle pulse is high at the end of the envelope the generator recycles itself.

The End pulse is put out at the end of the cycle, but only if triggered at Start input-not if cycled.

The window is a period of time which can begin anytime during the cycle. The beginning point of this window is controlled by the window position pot; and the window size VC in.

At the beginning of this period the window pulse out goes high and remains high for the duration of the window.

The Hold - when the hold input goes high the envelope stops and maintains the level it is stopped at.

NOTE: ON THE TOP RIGHT HAND PANEL: THE RIGHT HAND ENVELOPE GENERATOR IS ARRANGED SO THAT THE HOLD IS ONLY OPERATIVE WHEN THE WINDOW PULSE IS HIGH. ON ALL OTHERS THEY ARE INDEPENDENT.

To get, for example, the following envelope then:

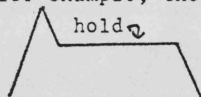

(Or any position of hold desired) the following steps are necessary:

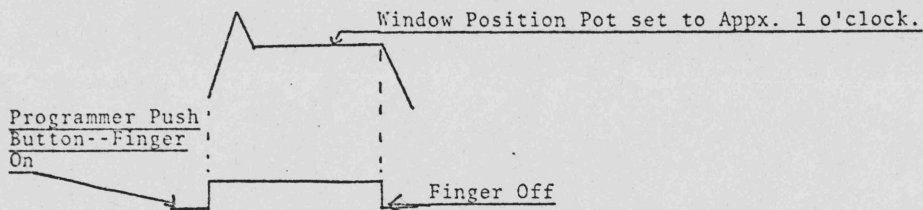

(The Programmer Push Button Pulse Out Must be connected to BOTH Start and Hold Inputs)

OR: To get Voltage Control of both When the Hold Begins and How Long It Lasts The Following:

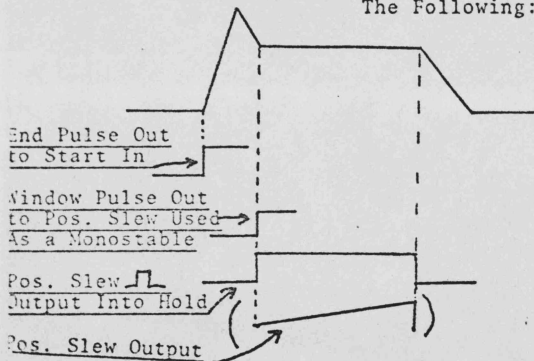

Apply Control Voltages to Window Size and VC In on Pos. Slew

The Window Size Control Voltage will position the hold. The VC In on Pos. Slew adjusts the length of the hold.

(can be used as aux. envelope)

The envelope generator can be used as a sub-harmonic generator, an (inaccurate) sample and hold (via window size) and as a staircase generator, among others.

Negative and positive slews can be concatenated with multiple envelope generators- to give ultra complex multiple output envelope generation.

NEGATIVE SLEWS (Dual Module)

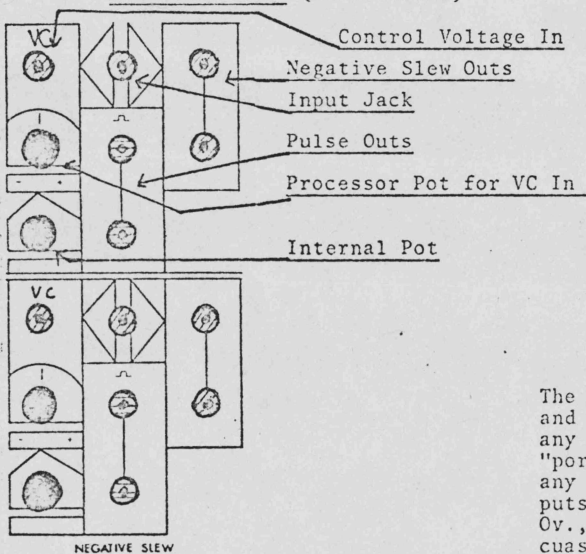

The negative slew accepts a voltage and follows (i.e., outputs) exactly any rising voltage but "slews" or "portament" or "integrates" between any falling voltages. This module puts out a pulse when it reaches 0v., which if put back into the input causes the Neg. Slew to oscillate. SLEW TIME is controlled by both an internal pot and a control voltage in with a processor pot. Appx. range is 1/30 cps \rightarrow 500HZ (and higher with control voltage in.)

Uses of the Negative Slew include:

1. ENVELOPE GENERATION - DECAY ONLY
2. Audio oscillator sawtooth.
3. Negative sloping Voltage Control Slope Control (very accurate)
4. ENVELOPE DETECTION (HALF-WAVE) with Voltage Control of Decay Slope.
5. Trigger pulse source (voltage controllabl

POSITIVE SLEWS (dual module)

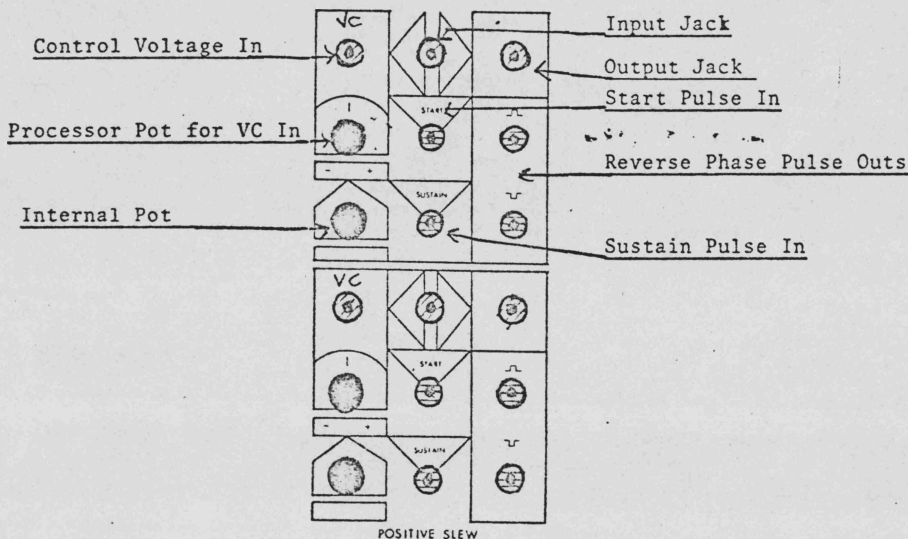

POSITIVE SLEW (dual module) This is similar to the negative slew except that it slews between rising voltages (at its input) and follows exactly falling voltages.

The START input allows it to be triggered like an envelope generator. It's DURATION is controlled by an Internal Pot and Control Voltage In with Processor Pot. This module puts out a pulse when it reaches +5v. The Sustain input holds the voltage at +5v. for the duration of the input pulse.

- The uses of this module include
- 1) ENVELOPE GENERATION (rise only)
 - 2) a) monostable pulse source (triggered by a pulse, a pulse of a certain length determined by VC is generated.)
b) a source of voltage controlled delay of a second pulse.
 - 3) Low frequency sawtooth oscillator.
 - 4) Sub-harmonic generator (especially good when used with Waveshaping.)

- 5) Positive Slewing (negative slew is always as fast as what ever the input is).
- 6. Voltage controllable trigger pulse source.

The Negative and Positive Slews Together make:

1. One complete envelope generator with independent VC of rise and fall.
2. A complete portamento.
3. A non-linear (distorting) "low pass filter"- (good for removing clicks and transients from old records.)
4. Variable slope triangle wave generation.

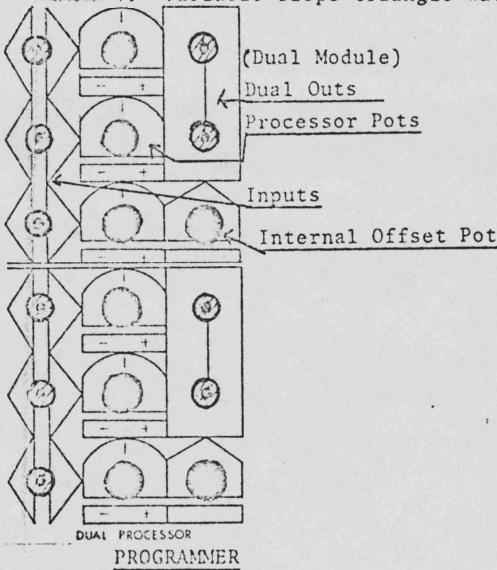

This is a very accurate mixer. There are 3 inputs with processor pots for each, from full inversion to full positive. Internal pot adds from 0 to 5v. to resultant. Though primarily designed as a control voltage mixer it can also be used as a phase-shifting audio mixer. At full left the input wave will be 180 degrees out of phase with the full right (non-inverted) position. At Center the wave is hulled out.

There are 4 stages each with 3 levels (top, middle, bottom). Depending on which stage the programmer is set to, that voltage appears at the output (on the side) - all three levels simultaneously.

Stages are set by either the push buttons below each stage, or its associated pulse input. When a new stage is set, a pulse is put out of the common P out; and the P out above the stage goes high and remains high until a new stage is set.

* common P out only gives out a pulse when push button is used.

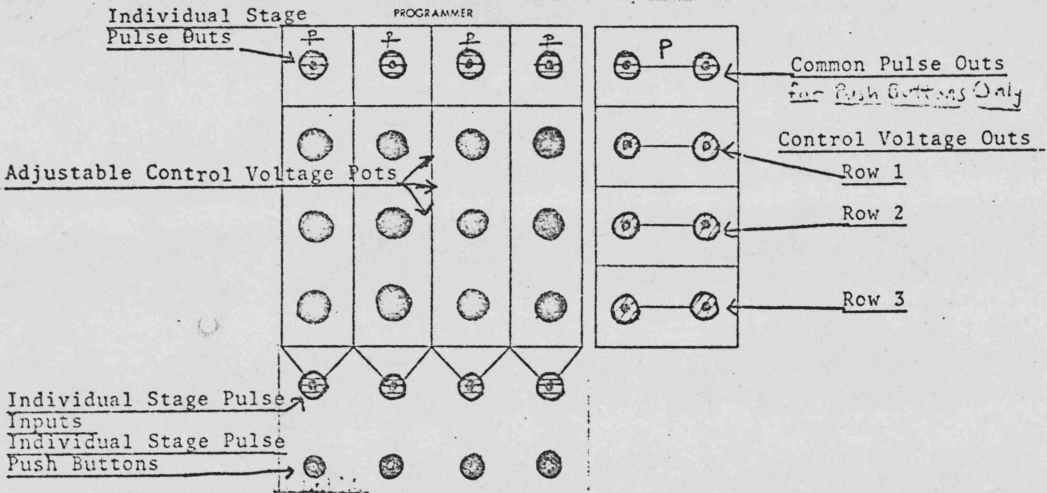
PROGRAMMER

MULTIPLES - There are many sets of multiples on this machine.

They are marked either M or Mults.

NEVER use these to mix pulses, audio, or control voltages ever!
 Because in doing so you have connected an output to an output,
A DISTINCT NO-NO.

SAMPLES OF MULTIPLES

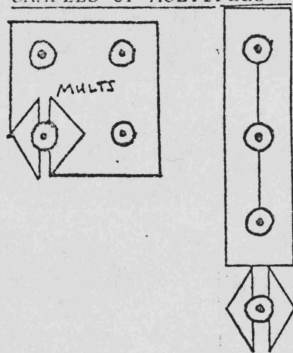

AFTERWORD

This a unique machine, designed to break down traditional synthesizer functions into simpler units more compositionally useable and combinable than were such functions before. Your discovery of many of its unique properties depends strongly on your willingness to explore it and approach it without preconceptions, to work with it on its own terms.